

Lens Wonderland

Canon FD Lens Guide Book

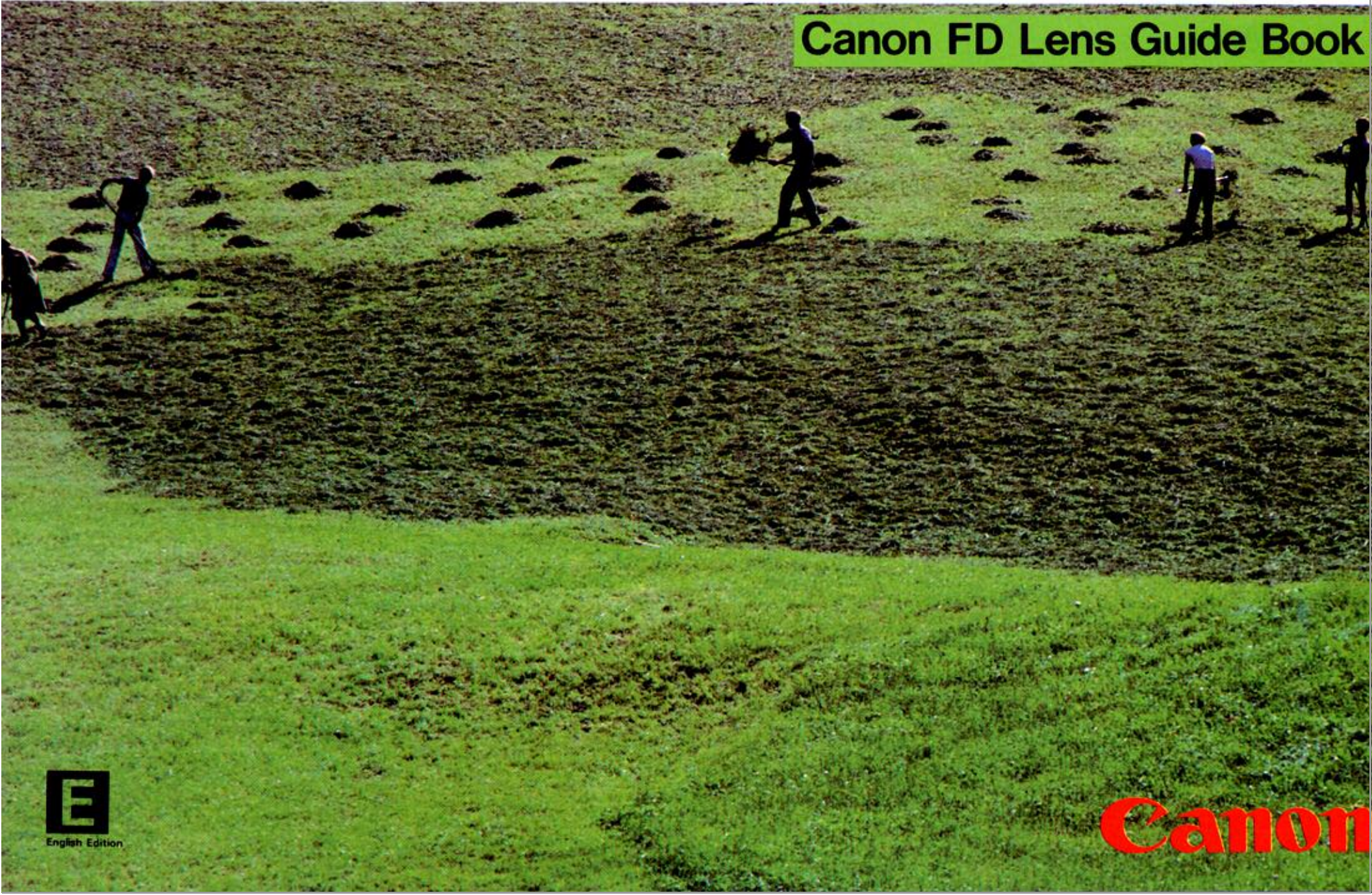

Canon

CONTENTS

Step into a Wonderful World	1
Lens Basics	7
The Interchangeable Lens	8
Angle of View.....	10
Perspective.....	11
Depth of Field	12
Aperture Ratio.....	14
Lens Buying Seminar.....	15
The Basic Lens System	16
Selecting the Right Lenses for You	18
Performance Check 1	20
Performance Check 2	21
Performance Check 3	22
Performance Check 4	23
The Professional Choice	24
Lens Workshop.....	25
Snapshot Zoom	26
Travel Zoom.....	28
Portrait Zoom.....	30
Sports Zoom	32
Wide Shots	34
Telephoto Shots.....	36
Macro Shots.....	38
Accessories Guide I & II.....	40
Specifications.....	44

Step into a Wonderful World.





Tight framing and the bright colors provide a symmetry of balance to this beach scene. Choice of a wide aperture and the telephoto's shallow depth of field throw the white-capped waves in the background out of focus to emphasize the subject.

FD75— 200mm f/4.5, 1/250 sec. at f/5.6 ISO64



Suspended in space and time, this modern-day Icarus obviously has no qualms about flying too close to the sun. The bright sunshine glistening on the wings and pilot's helmet highlights detail and allows a fast shutter speed to be used. The scene is perfectly framed with the zoom lens at its 300mm setting.

FD85-300mm f/4.5, 1/500 sec. at 1/5.6, ISO 64



Two little girls in a park. Completely absorbed in their play, they are unaware that their picture is being taken. Children are full of energy, never staying for more than a moment in one place. Knowing this, the photographer used a medium wide angle lens, stopped down for greater depth of field.

FD35mm f/2, 1/125 sec. at f/8, IS064



The audience goes wild as the drum solo reaches its climax. Shooting from the foot of the stage, the photographer uses a 200mm lens to bring the spot-lit drummer right in close. He keeps his elbows pressed tightly to his body to minimize camera movement.

*FD200mm f/2.8, 1/500 sec. at f/2.8,
ISO 200 pushed to EI 400*



Photography can help us unravel life's mysteries. This cicada emerging from its cocoon will live only 10 brief days before dying. A half life size shot, taken at a distance of 45mm with a 100mm macro lens and Macrolite ML-1 flash. Single-head illumination from the left.

FD100mm f/4 Macro, 1/60 sec. at 1/16, ISO 64

Lens Basics

One of the greatest features of SLR cameras is their ability to accept a variety of interchangeable lenses. The minute you mount a wide-angle lens onto your camera, you'll see the world from a broader perspective. And when you replace your standard lens with a telephoto, the faraway comes in close, filling the frame beautifully. With different lenses to work with, you'll be amazed at how much more you can express with your camera. But first, take some time to learn the basics behind lenses.



Nearing Human vision or surpassing it: the interchangeable lens.

■ Zoom Lenses

The human eye is the all-purpose lens: it focuses precisely on whatever it chooses. Interchangeable lenses make it possible for the photographer to come close to duplicating — even surpassing — this capability. That's why Canon provides almost 60 different interchangeable lenses for just as many different applications. Standard lenses give a natural-looking perspective which closely approximates human vision. These have large apertures, which make photography in dimly lit rooms as well as low-light outdoor scenes possible. But for the really exceptional shot — a soaring bird, or the minute details of an insect's wing — standard lenses won't suffice. Distant subjects require telephoto lenses, whereas subjects almost too small to see call for macro lenses. When a broad field of view is the target, wide-angle lenses accomplish the task. Near or far, great or small, different lenses are needed for attention-getting pictures.



■ *Wide-angle and super wide-angle lenses*



■ *Standard lenses*



■ *Telephoto lenses*



■ *Super telephoto lenses*



■ *Macro and special lenses*



■ *Other lenses*



Take in a little, or a lot — Angle of view.

If you're familiar with photography, you probably already know that focal length governs angle of view. If taken from the same position, longer focal lengths produce larger images, whereas shorter lenses provide broader angles of view. But there is more to angle of view than this. Look at the two pictures below made with telephoto lenses, a 100mm and a 200mm. The girl clearly becomes the main point of attention. Notice how her personality is easily conveyed in the telephoto pictures. With the 28mm lens, on the other hand, the scene takes on quite a

different feeling. The girl harmonizes with the background, and the shape of the windows and railing takes on more importance in the picture. In other words, telephoto lenses are ideal when you'd like to emphasize or bring a subject in closer. Wide angles are the choice when you want to give the subject's background equal importance. A zoom lens is particularly handy here because it lets you choose between wide and narrow angles without changing position or lens.

28mm



50mm



100mm



200mm

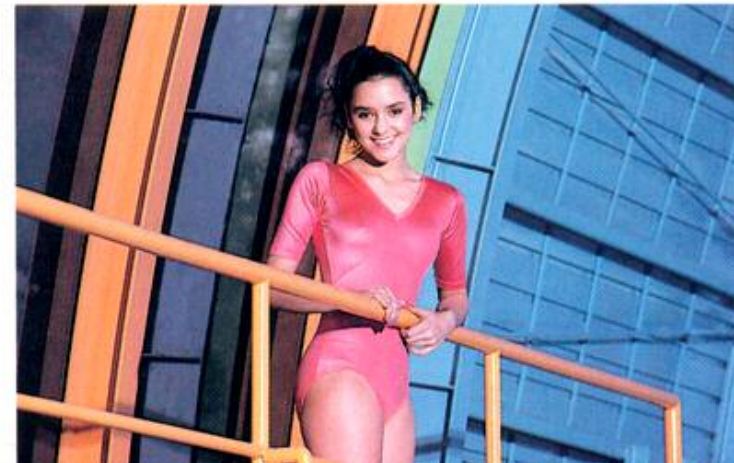

Wide angles for an exaggerated sense of depth; telephotos for flatness — Perspective.

Field or angle of view is not the only thing a photographer has to consider. Perspective, or the sense of depth, controls the spatial relationship between one subject and another. In the pictures below each focal length tells a different story. At 28mm, 50mm, 100mm, and 200mm, the camera was moved so that the subject's size remains the same in the images. The differences arise in the background. It seems to go on forever when a 28mm wide angle is used, but looks very close to the

subject when shot with the telephotos. That's why the best way to make a subject really stand out from its surroundings is to use a wide-angle lens and shoot from a relatively short distance. On the other hand, to create an image that appears "flat," use a telephoto lens and stand back. Here again, a zoom lens lets you get the perspective you want without having to change lenses.

28mm



50mm



100mm



200mm



How focal length and aperture affect focus range — Depth of field.

Depth of field, the range of sharpness in front of and behind the subject on which focus has been set, is best understood by examining the photographs below. When the majority of subjects appear sharp in a picture, the depth of field is great; when they

appear sharp within a narrow range, the depth of field is small. Depth of field varies according to the focal length and brightness of the lens used and the distance from which the picture is taken.

f/1.4

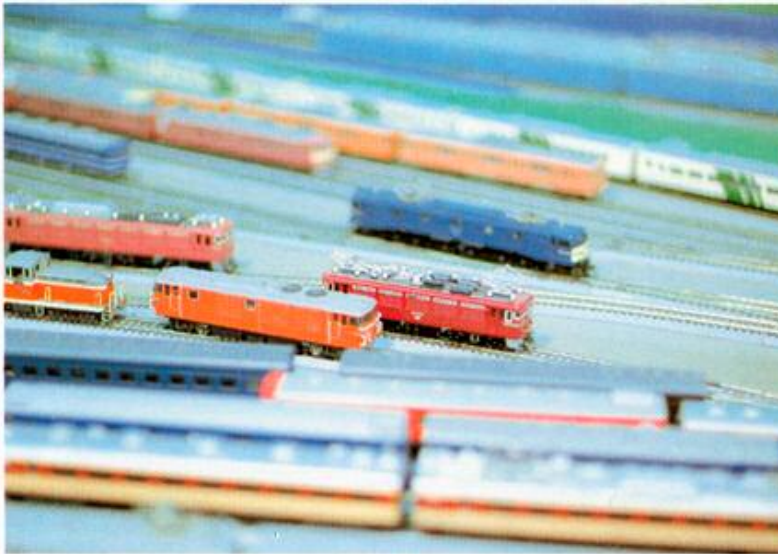

f/8



f/4



f/16



- **Depth of field is narrow at wide apertures, greater when the lens is stopped down.**

The four pictures at left were taken with the same lens from the same distance, but at different apertures. As you can see, the more the lens is opened, the narrower the depth of field becomes; the more the lens is closed, the greater the depth of field. By using a large aperture such as $f/1.4$, you can make the background and foreground appear blurred, and by stopping the lens down as much as possible (to $f/16$ or so), the entire picture will be sharp. Blurred backgrounds call attention to the main subject and de-emphasize unnecessary details; sharp backgrounds tend to portray the subject in its overall surroundings. In other words, the aperture should be varied to suit the mood and nature of your subject.

- **Depth of field is greater with wide angles, smaller with telephotos.**

The pictures to the right were taken from the same distance, but with 28mm, 50mm, and 135mm lenses. An aperture of $f/4$ was used in all cases. By comparing the enlargement of the 50mm shot with the 135mm shot, you can see that depth of field is greater with the 50mm than it is with the 135mm telephoto lens. Depth of field is greatest with the 28mm lens. Thus, given the same aperture, depth of field is deeper with wide-angle lenses than it is with telephotos.

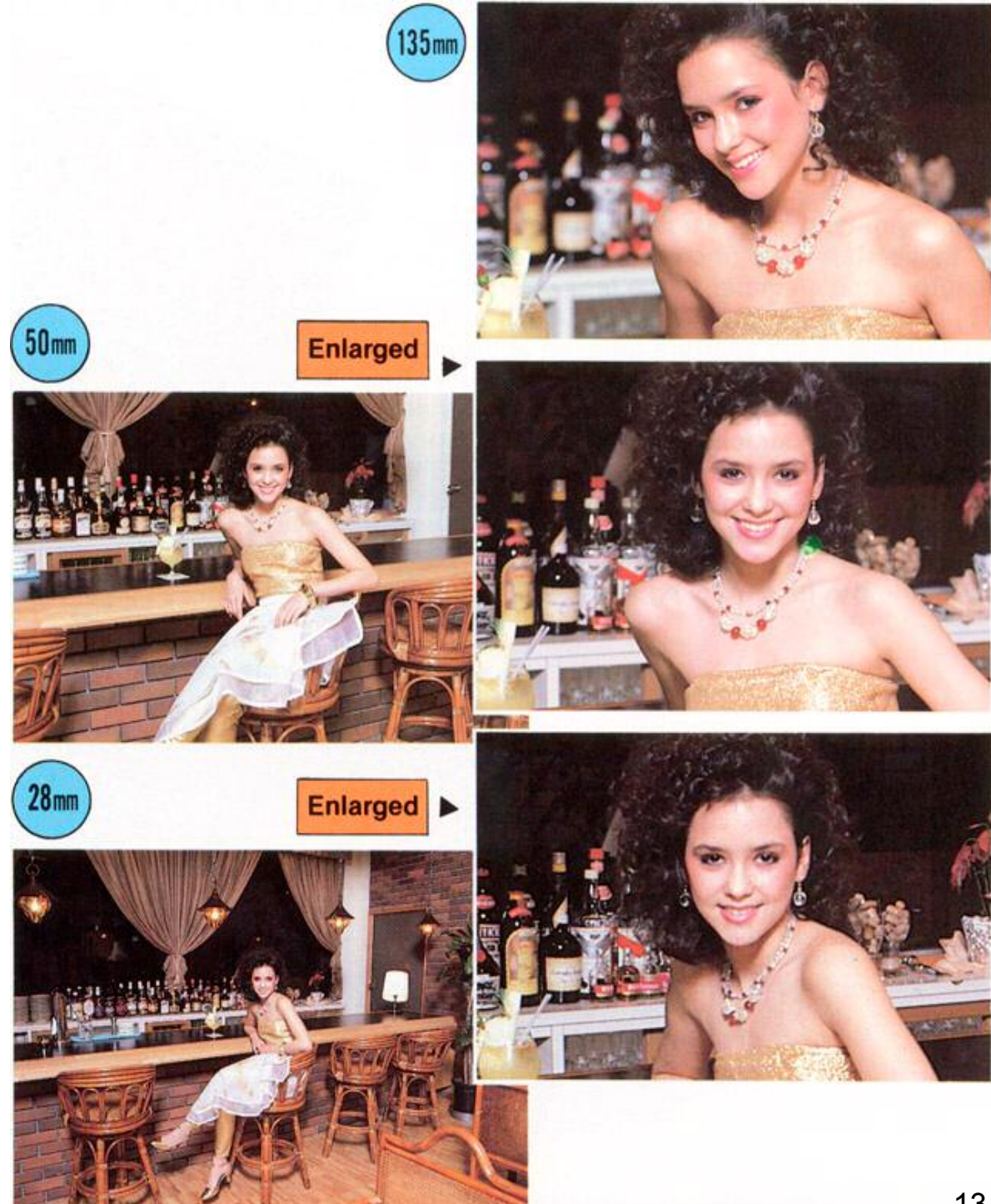

The larger the lens opening, the brighter the lens — Aperture ratio.

The brightness of a lens is expressed in terms of its aperture ratio (the ratio of the lens's focal length to the diameter of the lens opening). Thus, the "1.4" in the FD 50mm f/1.4 standard lens indicates the aperture ratio, an abbreviation of 1:1.4. The lenses with the smallest aperture ratios are the brightest. Since the lens opening of such lenses is large compared to their focal lengths, they are capable of transmitting relatively large quantities of light. For example, Canon produces two different 135mm telephoto lenses, one with an aperture of f/2.8, the other, with an aperture of f/3.5. The f/2.8 lens is the brighter of the two. This can be confusing when purchasing a lens, but in

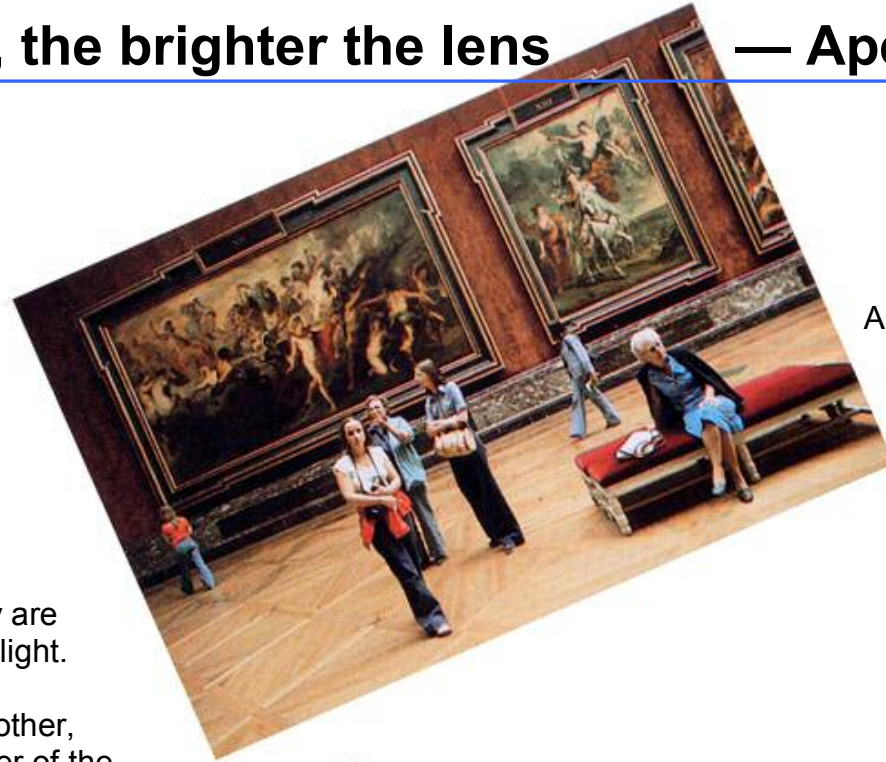

A fast lens lets you shoot without flash even in a dimly-lit museum.

general it is best to select the brightest lens which your budget allows. Brighter lenses make night-time hand-held photography easier, and permit shooting under most low-light conditions. They're also useful when flash is not permitted, such as in art galleries or theaters.

You need maximum brightness for theater photography. Use of wide apertures permits fast shutter speeds.

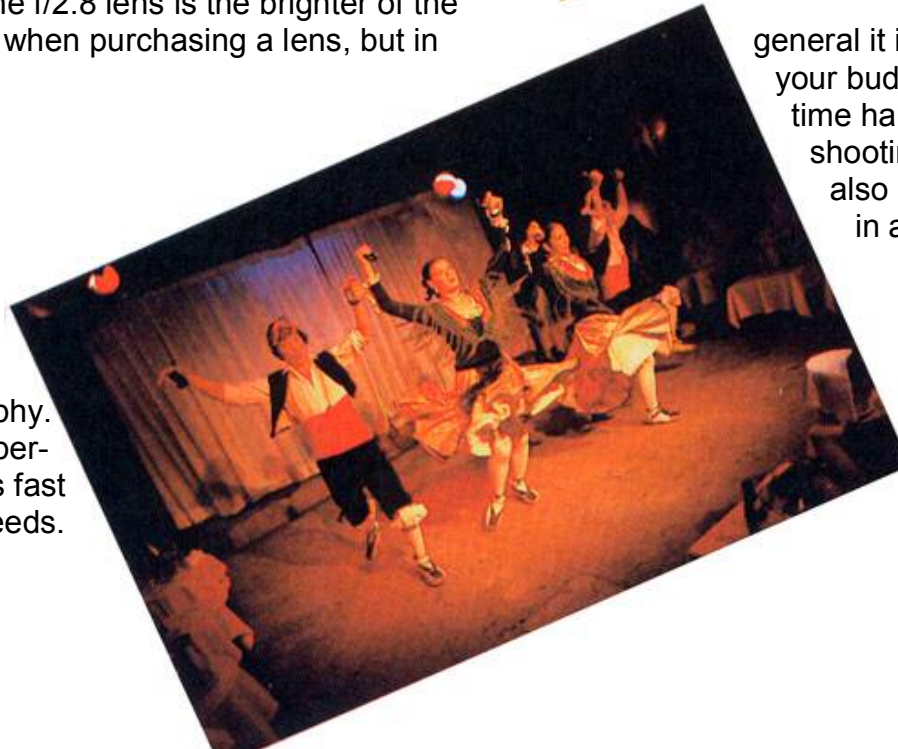

Lens Buying Seminar

As shown in the previous section, interchangeable lenses share the same basic flexibility and characteristics. However, although they have many similar features, these lenses are actually quite different. Each Canon lens is suited for different photographic applications, not to mention various budgets and tastes. Here are some points to think about when making your lens selection. Since there is such variety among FD lenses, you can select the combination of lenses which best meets your needs.



Wide-angle, standard, telephoto. The three focal lengths to include in your basic lens system.

The first step in selecting interchangeable lenses is to develop a clear idea of the kinds of subjects you want to photograph. For example, if you do a lot of traveling, a single, versatile zoom lens is the practical choice. Telephotos or super telephotos are appropriate for sports, wildlife, or birds; both a wide-angle and a telephoto are necessary for landscape photography. A macro lens is almost indispensable when it comes to shooting plants, flowers, or insects. Most people don't limit themselves to photographing only one type of subject, however. They want enough flexibility in their lens system to take shots of the family, travel scenery, sports events, and other subjects. To achieve this flexibility, it's a good idea to start by assembling a basic lens system.

- **Select a combination including focal lengths of 28mm, 50mm, and 135mm**

Selecting one lens each from the wide-angle (28mm to 35mm), standard (50mm), and telephoto families (85mm to 300mm) lets you photograph almost any subject you are likely to encounter. The 24mm and 28mm wide-angle range provides substantial depth of field, deep perspective, and a wide angle of view ideal for scenery, groups, and indoor photography. The 85mm, 100mm, and 135mm telephotos are best for candid "people" shots or for flattering portraits, while the 200mm and 300mm telephotos come in handy at sports events or for compressing scenery. Canon's 28mm, 50mm, and 135mm lenses are especially easy to use and lightweight, so you can't go wrong if you center your lens system on these basic three.

- **Zoom lenses provide great versatility**

Zoom lenses are a great alternative, because one single zoom lens can cover the range of several fixed focal length lenses. The continually variable focal length of zooms allows you to photograph subjects in a variety of different ways without changing your standing position. Canon zoom lenses have an established reputation for high resolution, superb color

A basic system comprising 28mm, 50mm, and 135mm fixed focal length lenses



balance, and easy handling. This, together with the ability to "close in" on subjects without changing lenses, makes Canon zooms the increasingly popular choice among people putting together a basic lens system. Some possible combinations include: 1) a 35–70mm zoom lens as the standard lens, a 28mm wide-angle, and a 75–200mm telephoto zoom; 2) a 35–

105mm zoom together with a 100–300mm zoom; 3) a 28–55mm zoom and a 75–200mm zoom; and 4) a 50mm–135mm zoom together with a 28mm wide-angle. Light AE SLR cameras plus versatile zoom lenses make perfect partners, so a basic lens system comprising zooms is an intelligent choice to make.

A basic system including 28–55mm, 35–105mm, and 100–300mm zoom lenses

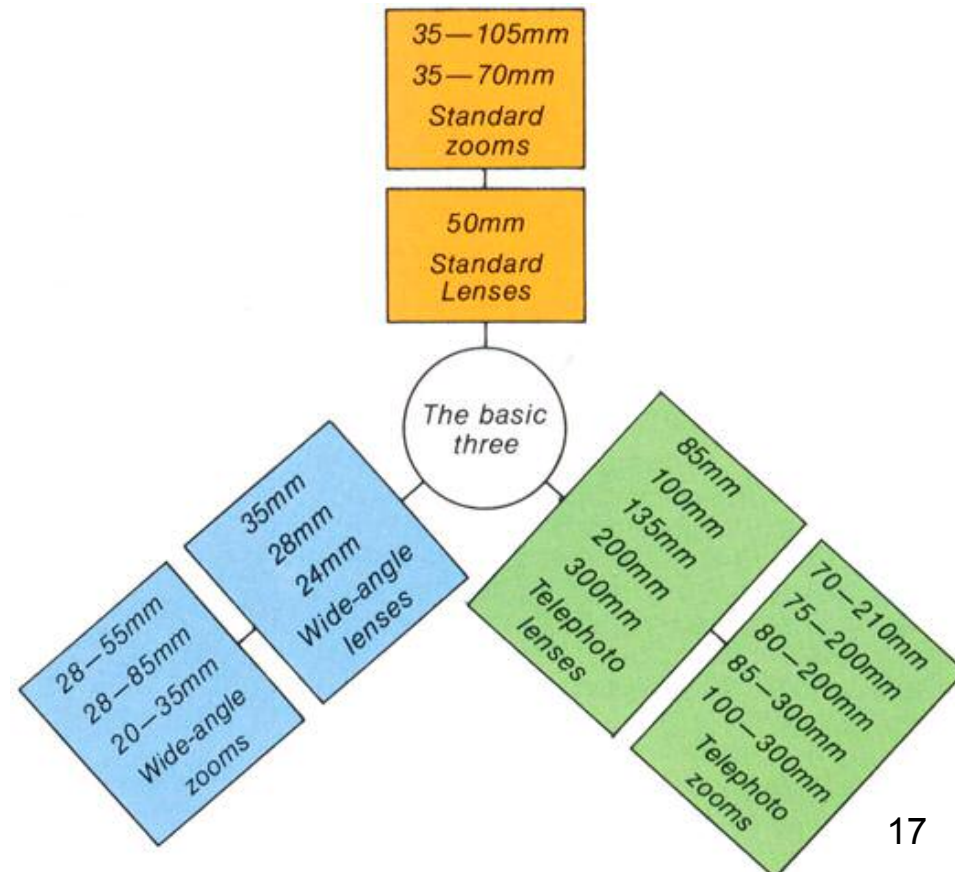

Select lenses that suit the type of photography you do.

When building your basic lens system, that is, lenses for use within the normal range from 24mm to 300mm, set up a buying plan in advance and identify your photographic objectives. Here are several popular combinations for various types of photography, all of which are reasonably priced.



• Commemorative photos and snapshots

When your primary goal is to take candid shots, you can't go wrong selecting a 35–70mm zoom as your standard lens. With this single lens, you can take both group and individual portraits. By adding a 135mm telephoto to the system, you'll be prepared for situations that demand more reach.

- ① FD35–70mm f/3.5-4.5 + FD135mm f/2.8
- ② FD35–70mm f/3.5-4.5 + FD75–200mm f/4.5

• Travel and scenery

The 35–105mm f/3.5–4.5 zoom is great for travel because you can photograph a mountain range one minute and zoom in on a wildflower the next. Best of all, you're not burdened with extra weight, because one lens is all you need bring on your travels. A 28mm or 200mm lens extends your basic lens system, and gives you extra flexibility.

- ① FD35–105mm f/3.5-4.5 + FD28mm f/2.8
- ② FD35–105mm f/3.5-4.5 + FD200mm f/4



• Sports

At the most exciting sports events, often it's impossible to get close enough to the action. A Canon 100 – 300mm f/5.6 is ideal for these situations. Combined with a power winder or motor drive, you'll be equipped to take those dynamic, arresting shots that are the trademark of sports photography.

- ① FD100-300mm f/5.6 + FD35mm f/2.8
- ② FD35-70mm f/3.5-4.5 + FD300mm f/4

• Portraits

The goal here is to convey the subject's personality as naturally as possible despite the posed setting. The traditional lenses for portrait photography are the 85mm and 100mm lenses. These focal lengths are covered in a 75–200mm zoom. Completing your system with a 35mm wide-angle allows further variety in composing portraits.

- ① FD75-200mm f/4.5 + FD35mm f/2
- ② FD35-70mm f/3.5-4.5 + FD100mm f/2.8

• All-around photography

For those who want to touch all bases, a combination of zoom lenses covering the range from 28mm to 200mm or 300mm is a wise selection. That way scenics, face shots, or architectural details are always within your reach. Two zoom lenses make for a comprehensive yet portable system.

- ① FD28–55mm f/3.5-4.5 + FD75–200mm f/4.5
- ② FD35–105mm f/3.5-4.5 + FD100–300mm f/5.6

Performance check 1: The sharpness of Canon FD lenses covers all corners of the image.

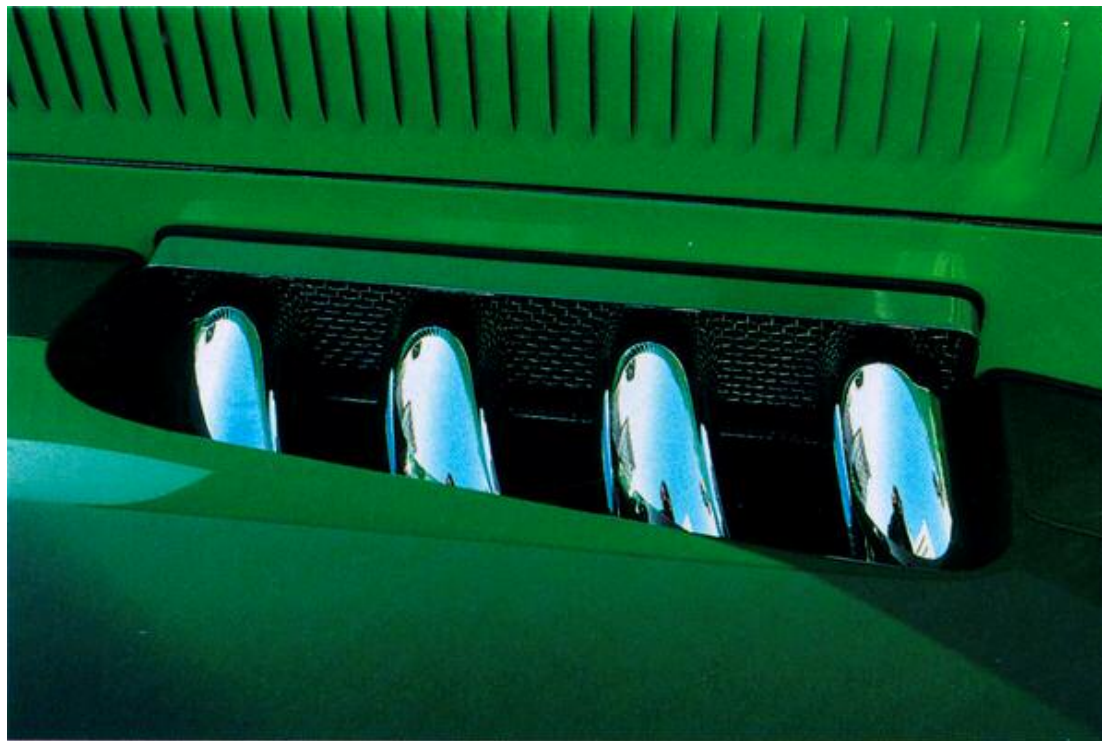

Taken with a Canon FD lens. Sharpness, form, and color create a look of quality.

Without a lens, a camera alone won't get you very far. This vital addition to the camera should be like a best friend: compatible, loyal, unflinching. It follows logically that the best companion to your Canon SLR is a Canon FD lens. Designed and built according to the exacting standards of Canon's top-of-the-line SLR, the F-1, FD lenses are all of equally high quality. Here are some tips on checking aspects of lens performance that don't show up in the specifications. Of course, you can be sure that all Canon FD lenses perform beautifully in terms of optics, mechanism, and reproduction accuracy.

First is the issue of a lens's sharpness. A lens can only be considered truly sharp if it has both the resolving power to produce fine details in the image and the contrast to accurately reproduce shadow gradations. Alone, neither can render true sharpness. If a lens is capable of contrast only, details are lost when a picture is greatly enlarged. The picture above, taken with an FD lens, is extremely sharp; this sharpness would be retained even if the picture were enlarged to poster size.

Performance check 2: Canon FD lenses faithfully reproduce the colors of the world



Taken with a Canon FD lens. White snow and blue sky, form a striking contrast.

The second point to check is the lens's color balance. It seems natural for a lens to accurately reproduce all the colors in an image. But without careful attention to such design factors as coating, differences in light wavelengths, illumination levels, angle, lens thickness, and configuration, a lens cannot faithful-

ly reproduce colors. The tendency for whites to come out reddish or yellowish in pictures taken with lower-quality lenses is completely corrected with FD lenses. And since all FD lenses have a special spectral coating, from the fisheye all the way up to the super telephoto, true-to-life reproduction can be achieved.

Performance check 3: Canon FD lenses are lightweight and compact without sacrificing top performance.

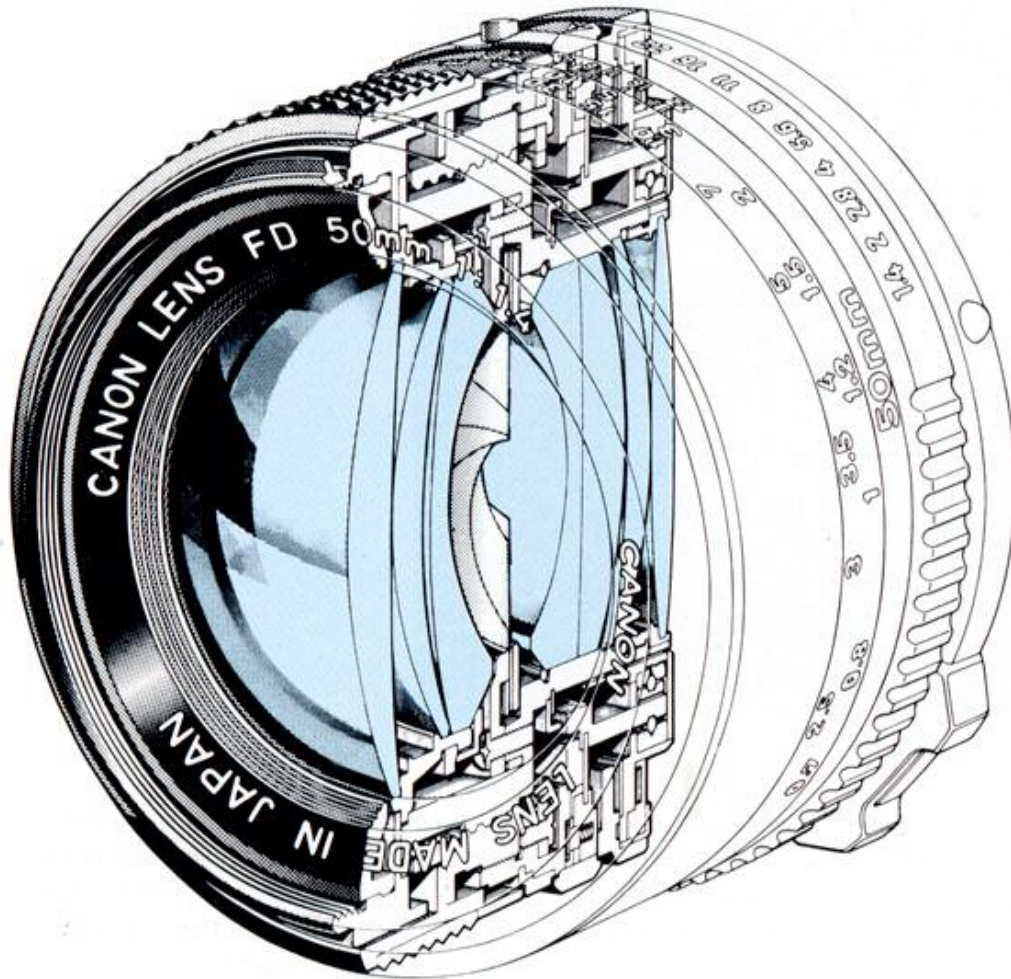

Virtually all lens manufacturers claim their lenses are lightweight and compact. But unless lenses are sharp and well-balanced, the purpose of this feature is defeated. Since there are inherent factors limiting the degree to which lenses can be reduced in size, images will deteriorate at full aperture if these limits are exceeded. When buying any lens, look out for lens barrels which feel stiff and don't rotate as smoothly as FD lenses during focusing and zooming. Also beware of lenses which have rattles or stiff focusing/zooming rings now — they often cause problems later on. The true test of a lens is how well it wears with use, and FD lenses pass this test with flying colors.

Performance check 4: Canon FD lenses, designed to the exacting standards of the F-1



In order for a lens to operate smoothly and harmoniously with a camera, the coupling mechanism must be precisely built. Lenses produced by camera manufacturers are designed with signal pins, mounting mechanisms, and focus detection mechanisms which ensure that the cameras will always live up to their full potential. After-the-fact lens manufacturers, however, do not always consider factors such as focusing screen optics, and often the image will appear to be in focus in the center of the viewfinder, but out of focus around the edges. This kind of problem typically occurs because the lens is designed without due consideration of the characteristics of the camera body.



Accurate focus is achieved with FD lenses and Canon SLRs.



With lower-quality lenses, the image is out of focus.

Why do professionals choose Canon FD lenses?

The sharpness and fine color balance of this picture demonstrate the accuracy of Canon FD lenses which incorporate UD glass.



No one selects lenses more carefully than professional photographers. Their lenses must perform reliably under a wide range of harsh conditions; moreover, to fully test the powers of photographic expression, professionals demand lenses with outstanding performance, strength, and ease of handling. Many professionals use Canon FD lenses exactly for these reasons. Also, the great variety, the availability of high-performance "L" series lenses, and Canon's worldwide reputa-

The aspherical element in this "L" series lens helps produce images free of flare even at full aperture.



tion explain why you see so many professionals with FD lenses — *and* why Canon has often been designated the official camera of the Olympics. Also, professionals tend to place greater importance on the quality of lenses than the camera body itself; some go so far as to regard the body as a mere box for holding the film. The marked preference of professionals for Canon FD lenses indicates the high reputation of Canon's lens technology.

Lens Workshop

What is the best lens for a given subject, and how can it be used to develop that subject? Here are practical techniques for using lenses, starting with zooms. Whether your interest is people, scenery, action shots, or fine details and still lifes, you'll discover your own personal style of photographic expression through combining the talents of you and your lenses.

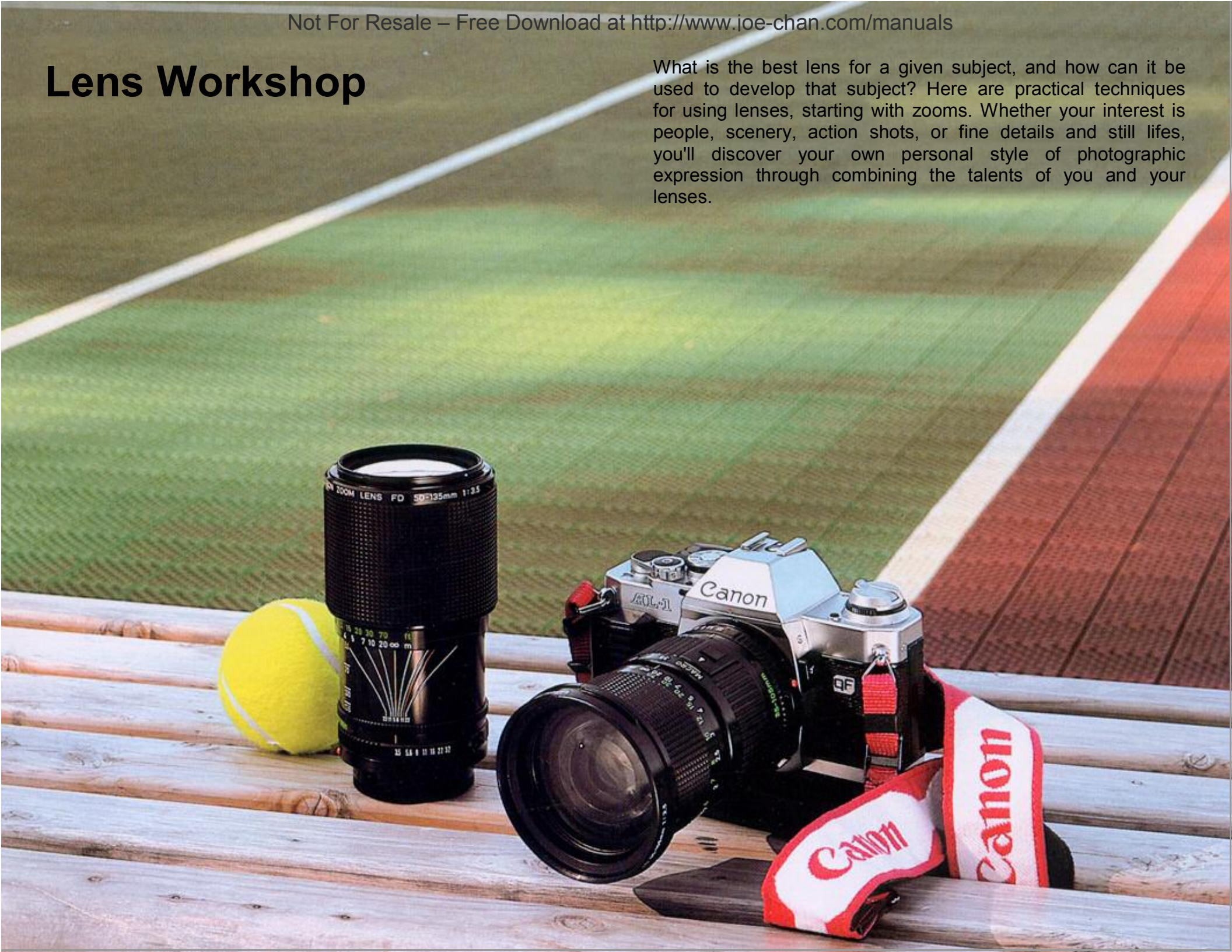

Snapshot Zoom

Capturing special moments from day to day.

What is a snapshot? It's a scene that catches your eye or an event that catches your heart. It's capturing a special mood or a fleeting expression. Because even a contemplative picture like this often requires spur-of-the-moment camera work, you need a responsive lens. Simply put, nothing meets these needs better than Canon's FD 35—70mm f/3.5-4.5 zoom. A lens which quickly displays its versatility, it moves from a 35mm wide-angle shot to a 70mm portrait in just moments. That way, you can photograph the whole group, or, without moving, zoom in on one special person. The lens's compact size makes it easy to take a series of shots in rapid succession, or to take "blind" shots holding the camera at waist level or overhead. Use the telephoto when you want some distance between yourself and camera-shy subjects. You'll also appreciate the extra flexibility you'll get from using this lens with a power winder.



FD35- 70mm f/3.5-4.5, 1/125 sec. at 1/5.6, IS064



Travel Zoom

With a single lens, capture a far-off landscape or a colorful festival.



Travel offers infinite photographic possibilities, from the scenery you glimpse through your car window to the undiscovered corners of a quaint village. Because of the wide variety of subjects you encounter, you need a lens that can do them all justice. With a 3x zooming ratio, the FD 35—105mm f/3.5-4.5 is just the lens because it can handle the demands of an expansive landscape, an interesting detail, or the playful smile of a child. Of course, it can also be used for grab shots, portraits, and commemorative photographs. It is compact for easy carrying and offers limitless applications. It may very well be the only lens you need on your travels.

FD35-105mm f/3.5-4.5, 1/250 sec. at f/11, IS064



Portrait Zoom

Approach even the dauntless with a telephoto lens.



The four key points to better portraits are: 1) use a telephoto lens, 2) blur the background, 3) place your subject in flattering lighting, and 4) focus on your subject's eyes.

Using a focal length of 85mm or 100mm results in more natural-looking portraits; also, your subject feels more comfortable since you don't have to stand directly in front of him or her. Focus carefully on the eyes, the most revealing part of a person's face. Open the lens aperture as much as possible to throw the background out of focus, and place your subject in appropriate lighting (for women, soft indirect lighting may be suitable; for the portrait at left, side lighting was used for an intense effect). The Canon FD 75—200mm zoom lens itself to portrait photography beautifully. As well as covering the focal lengths from 85 to 135mm, its 200mm telephoto setting allows you to capture natural expressions and gestures from several meters away.

FD75-200mm 1/4.5, 1/250 sec. at f/4.5 IS064



Sports Zoom

Combining telephoto lenses and high shutter speeds for breathtaking sports shots.



There's no question about the inherent drama of sports – the dynamism of the players, their concentrated expressions, and the atmosphere of heated struggle. A telephoto zoom lens like the FD 100–300mm f/5.6, combined with a shutter speed of 1/500 or 1/1000 sec., allows you to photograph these turbulent movements and emotions. The telephoto zoom singles out the action, while the high shutter speeds, along with high sensitivity film, freeze the instant of drama. A motor drive or power winder ensures that you never miss the crucial shot, and are always ready for the unexpected. One final tip: make sure your subjects fill the frame. Then you can be sure your sports shots always convey the action they represent.

FD100-300mm f/5.6, 1/1000 sec. at f/5.6, ISO200



Wide Shots

Exaggerate perspective with wide-angle lenses.

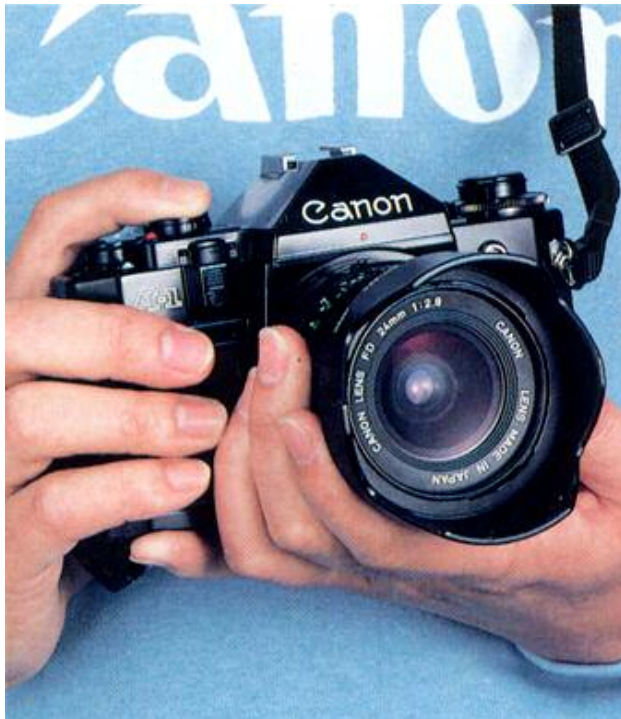

The foremost feature of the 24mm, 28mm, and 35mm family of wide-angle lenses is their broad field of view. With a 28mm lens, the amount of area included in the image is 2.5x that of a 50mm lens; with a 24mm lens, it is 3x. This is decidedly useful for scenery shots or for indoor photography. And since wide-angles also provide an exaggerated sense of depth, they can be used to alter the appearance of foregrounds or, when held at high or low angles, for interesting or humorous shots of people. Further, the great depth of field of wide-angle lenses means that pan focus pictures (in which everything in the image is in focus) are possible by stopping the lens down to f/16 or f/22.

FD24mm f/2.8, 1/60 sec. at f/8, IS064



Telephoto Shots

Compress space, draw distant subjects in close with telephoto lenses.

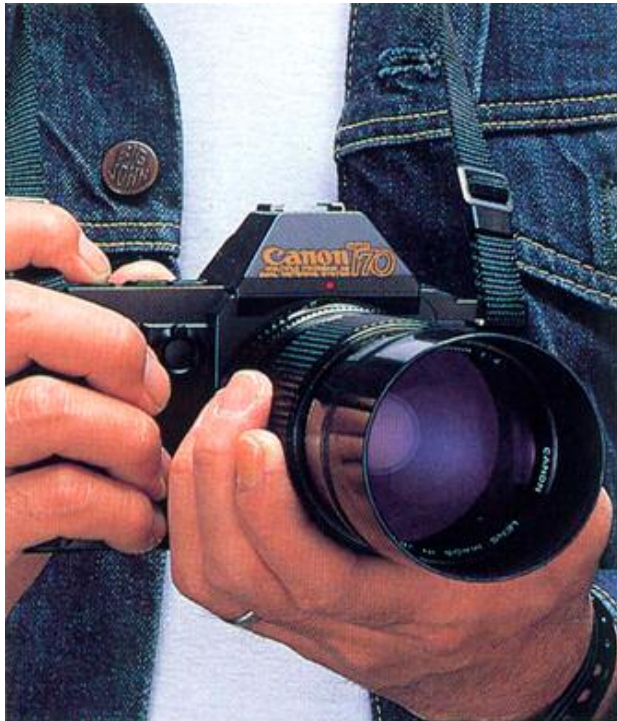

Meet the 100mm, 135mm, 200mm, and 300mm telephoto lenses. The 100mm lens is especially suited for natural-looking portraits and "people" photography. With its slightly longer focal length, the 135mm easily frames the features you want to emphasize. The 200mm and 300mm lenses provide a much narrower angle of view. They can single out subjects not easily resolved by the human eye, and their ability to compress space results in a pronounced telephoto effect. This makes them the best lenses for sports, wildlife, theater and aerial photography, as well as for scenery shots with a unique mood.

FD300mm 1/2.8L, 1/500 sec. at f/4, IS064

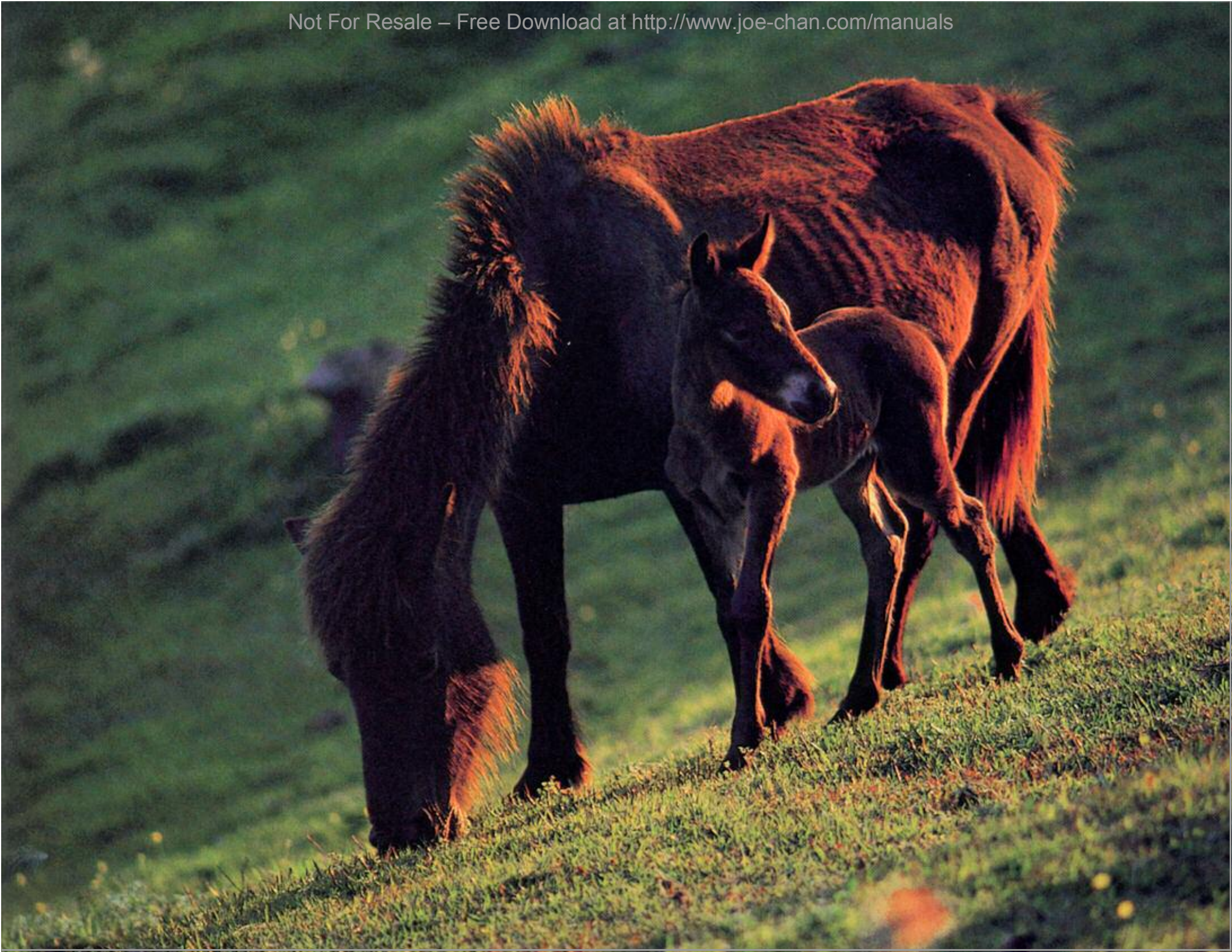

Macro Shots

Explore hidden worlds with macro lenses.

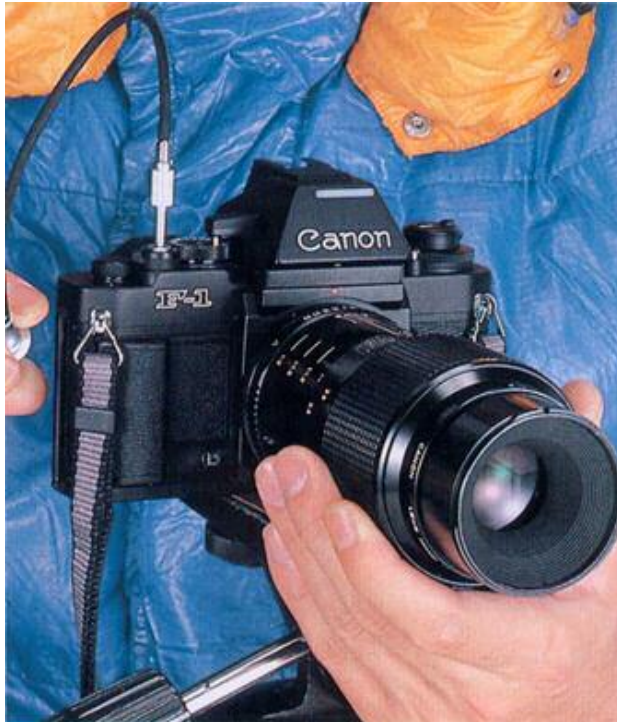

When you look through a macro lens for the first time, you find unexpected beauty in things you can't usually get close enough to see in great detail.

Whereas 50mm standard lenses provide images which are only 1/10 of life size, a 50mm macro lens by itself is capable of images of up to 0.5x. Still, their great magnification power doesn't exclude macro lenses from the realm of ordinary photography: these lenses can be used like a regular 50mm, 100mm, or 200mm. The 100mm macro is useful for taking photographs from greater distances (for example, when photographing insects which are likely to flee if approached too closely). The 200mm macro by itself is capable of providing life-size images, and is particularly effective with subjects which are difficult to approach.

FD100mm f/4 Macro, 1/30 sec. at f/11, IS064



Accessories Guide I

Interchangeable lenses open limitless new avenues to picture taking — from the expansive world of panoramas to the intricacies of closeups. With Canon accessories, you can discover even more. Like Canon FD lenses, Canon accessories form an incomparable match with Canon SLRs in terms of performance, precision, and reliability.

Power Winder A2

You won't miss another shot with a Canon power winder attached to your SLR. This accessory has become essential for sports, wildlife, and fashion photographers. The power winder is compact, easily mounted, and increases your versatility especially when used together with a zoom lens. The Canon Power Winder A2 (for "A" series SLR cameras) automatically advances the film at a rate of approximately two frames per second as long as the shutter button is held down. When a roll of film has been completely exposed or the battery drops below the minimum operating voltage, an automatic stop circuit turns the winder off and a red LED lights as a warning.



Speedlite 188A/166A

These two automatic flash units are great companions for Canon "A" series cameras. With these cameras (except for the AL-1 and AV-1), aperture is automatically adjusted to a predetermined value as soon as charging is complete. And as long as the shutter speed dial is not positioned at "B," all A-series cameras automatically set the shutter speed to 1/60 sec. (synch speed), even if you leave the dial at another setting. The 188A

and 166A, when attached to the AE-1 PROGRAM, inform you when the flash is charged, and provide a signal for auto-exposure confirmation as well. 188A, with a guide number of 25 (ISO 100-m) and 166A, with a guide number of 20 (ISO 100-m), both give an angle of illumination sufficient to cover a 35mm lens's angle of view. Aside from these, Canon's powerful, professional grip-type flash units 577G and 533G may be used for high-technique flash photography. The 199A, a clip-on type unit, is especially suited to the A-1.



Speedlite 277T/299T

In the "PROGRAM" mode, the 277T and the 299T set both the shutter speed and aperture automatically. In the "F.NO.SET" mode, you can choose from a wide range of eight apertures between f/2 and f/22. This enables you to take flash recycling time and depth of field into consideration. 277T has a guide number of 25 (ISO 100-m). 299T has a guide number of 30 (ISO 100-m) and additional functions of two MANUAL modes, a bounce flash and a built-in zoom mechanism.

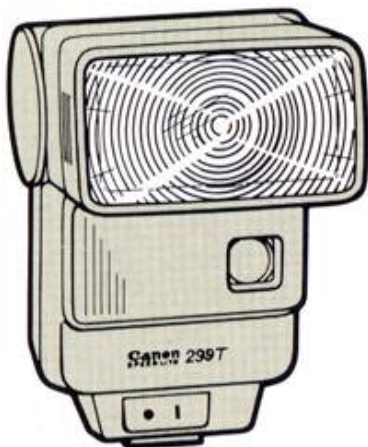

Data Back A

This accessory has numerous applications, from scientific to commemorative photography. The Data Back A makes it possible to record information such as the day, month, and year directly on the

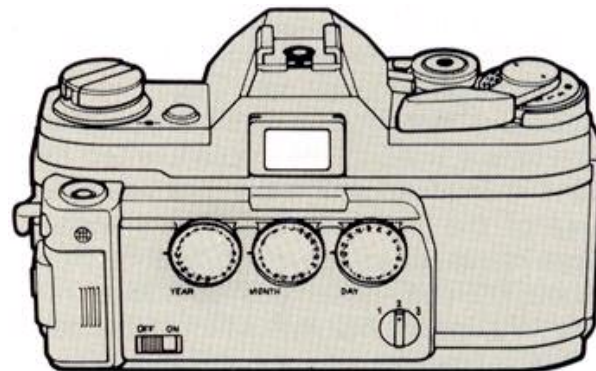

film the moment the picture is taken; it can be used with the A-1, AE-1 PROGRAM, and AE-1. Easily installed in place of the camera's regular back cover, its three dials can be set to automatically record a maximum of six numerals or characters. Manual recording is also possible.

Command Back 70

Designed exclusively for the Canon T70, the Command Back 70 is equipped with a command function that controls the camera in various timer modes such as a self-timer mode, interval timer mode, long release timer mode and frame counter setting mode. It also allows you to record data such as the day, month, year, time or frame counter directly on the film. The Command Back 70 can be programmed by combining the modes of the timer control function and using them together with the data recording function.

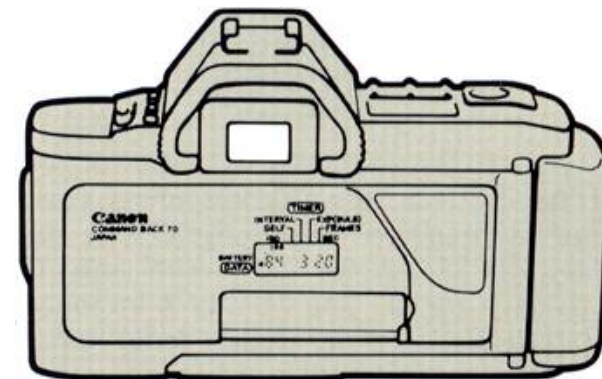

Accessories Guide II

Extender FD2x A/FD2x-B/FD1.4x-A

Use of a Canon extender means a single lens can be increased by a factor of 1.4 or 2, thus allowing one lens to serve the function of two. The FD2x-A, designed for use with 300mm or longer telephotos and the FD 200mm f/4 Macro, can double the focal length of the lens on which it is mounted. It can also be used with zoom lenses which include a 300mm focal length. For lenses (including zooms) which



have a maximum focal length of less than 300mm, the FD2x-B gives you a 2x increase in focal length. It is also recommended for use with the FD 300mm f/2.8L. The FD1.4x-A increases 300mm or longer fixed focal length lenses 1.4x. Naturally, all Canon extenders couple with the automatic diaphragm mechanism in the camera, so AE photography can be carried out as usual.

Close-up Lens 240/450

These convenient attachments are screwed onto the front of a lens, just like a filter, for easy closeup photography. There is little additional weight, and the main lens's aperture remains unchanged. These lenses are available in two types for all filter diameters: 450 and 240. These numbers stand for their focal lengths (mm) and are equal to the shooting distance in millimeters from the lens's front to the subject when the lens is focused at infinity. For example, use of the 240 with a 50mm standard lens increases image magnification from about 0.2 (1/5 of life size) to 0.35x; with the 450, image magnification is increased from about 0.1 to about 0.25x.

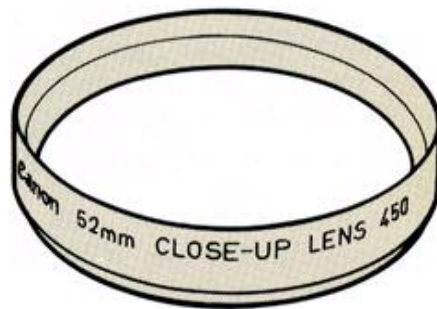

Extension Tube FD15-U/FD25-U/FD50-U

These 15mm, 25mm, and 50mm tubes let you take close-up shots when placed between the lens and the camera body. Since they synchronize with the camera's automatic diaphragm, AE photography is possible. When used with close-up lenses, even larger magnifications are possible.



Extension Tube M Set

This set includes one 5mm, one 10mm, and two 20mm tubes and can be combined to provide a total length of 55mm. Used in various combinations, suitable magnifications can be obtained for closeup and macro photography. For closeup photography, magnification provided when all five tubes are used in combination with a 50mm standard lens is greater than 1x, and even greater magnification is achieved when a close-

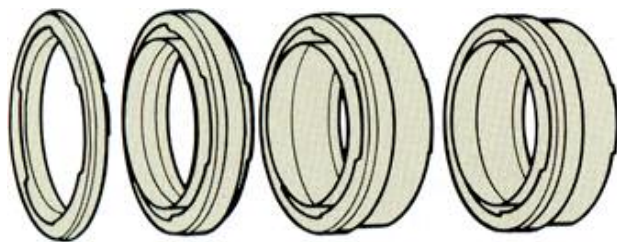

up lens is attached. Automatic exposure is possible when these tubes are used in conjunction with a macro auto ring and a double cable release. Diaphragm control is manual.

Vari-extension Tube M15-25/M30-55

These extension tubes feature adjustable lengths, simplifying focusing and magnification changes during close-up or macrophotography work. The M15-25's tube length can be adjusted from 15mm to 25mm; the M30-55's length can be adjusted from 30mm to 55mm. The former provides magnifications ranging from about 0.3 to 1x when used with a 50mm standard lens, and the range of magnifications provided by the M30-55 is 0.6 to 1.2x. When a close-up lens is used, magnification is 0.5 to 0.8x with the M15-25 and 0.8 to 1.4x with the M30-55.

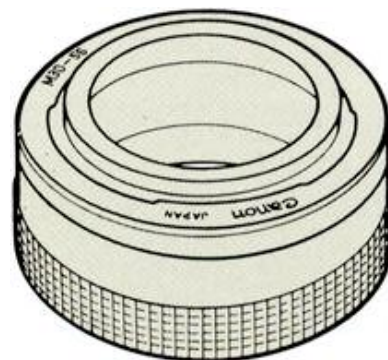

Auto Bellows

The Auto bellows, a high-performance accessory, forms the nucleus of Canon's close-up, macro, and copying systems. Used with lenses (including a standard 50mm) and other close-up accessories, it is capable of providing continuously variable magnifications within a fixed range. Also, when used with a double cable release, there is no need for manual aperture setting. Bellows length can be varied from 39mm to 175mm for magnifications ranging from 0.75 to 3.9x with a 50mm macro lens. Magnifications ranging from 1.3 to 3.4x are possible by mounting the lens in reverse. Backward

and forward movement of the bellows is controlled by means of a smooth, high precision rack and pinion mechanism. Focus is adjustable both on the camera side and the lens side, and the camera can be easily changed from the vertical to the horizontal position and vice versa. The Auto Bellows can broaden your

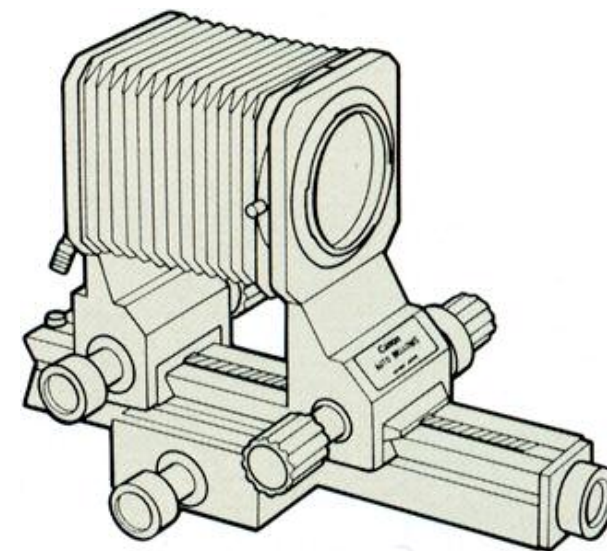

photographic horizons by letting you photograph natural crystals, jewels, and the extreme details of natural flora and fauna.

Canon Interchangeable Lenses

Type	Lens	Angle of View	Construction	Minimum Aperture	Closest Focusing Distance		Magnification at Closest Focusing Distance	Filter Size (mm)	Hood	Length		Weight	
					(m)	(ft)				(mm)	(in)	(gr.)	(lbs)
Fish-eye	Fish-eye 7.5mm f/5.6	180°	8–11	22	–	–	–	Built-in	–	62	2-7/16	365	
	Fish-eye FD 15mm f/2.8	180°	9–10	22	0.2	0.7	0.14	Built-in	Built-in	60.5	2-3/8	460	1
Super Wide Angle	FD 14mm f/2.8 L	114°	10–14	22	0.25	0.9	0.10	Built-in Filter Holder	Built-in	83.5	3-5/16	500	1
	FD 17mm f/4	104°	9–11	22	0.25	0.9	0.10	72	BW-72	56	2-3/16	360	
	FD 20mm f/2.8	94°	9–10	22	0.25	0.9	0.13	72	BW-72	58	2-5/16	305	
Wide-Angle	FD 24mm f/1.4 L	84°	8–10	16	0.3	1	0.12	72	BW-72	68	2-11/16	430	
	FD 24mm f/2	84°	9–11	22	0.3	1	0.11	52	BW-52C	50.6	2	285	
	FD 24mm f/2.8	84°	9–10	22	0.3	1	0.11	52	BW-52C	43	1-11/16	240	
	FD 28mm f/2	75°	9–10	22	0.3	1	0.13	52	BW-52B	47.2	1-7/8	265	
	FD 28mm f/2.8	75°	7–7	22	0.3	1	0.13	52	BW-52B	40	1-9/16	170	
	FD 35mm f/2	63°	8–10	22	0.3	1	0.17	52	BW-52A	46	1-13/16	245	
Standard	FD 35mm f/2.8	63°	5–6	22	0.35	1.25	0.13	52	BW-52A	40	1-9/16	165	
	FD 50mm f/1.2 L	46°	6–8	16	0.5	1.75	0.13	52	BS-52	50.5	2	380	
	FD 50mm f/1.2	46°	6–7	16	0.5	1.75	0.13	52	BS-52	45.6	1-13/16	315	
	FD 50mm f/1.4	46°	6–7	22	0.45	1.5	0.15	52	BS-52	41	1-5/8	235	
Telephoto	FD 50mm f/1.8	46°	4–6	22	0.6	2	0.10	52	BS-52	35	1-3/8	170	
	FD 85mm f/1.2 L	28°30'	6–8	16	0.9	3	0.12	72	BT-72	71	2-13/16	680	1
	FD 85mm f/1.8	28°30'	4–6	22	0.85	3	0.12	52	BT-52	53.5	2-18	345	
	FD 100mm f/2	24°	4–6	32	1	3.5	0.12	52	BT-52	70	2-3/4	445	1
	FD 100mm f/2.8	24°	5–5	32	1	3.5	0.12	52	BT-52	53.4	2-1/8	270	
	FD 135mm f/2	18°	5–6	32	1.3	4.5	0.13	72	Built-in	90.4	3-9/16	660	1
	FD 135mm f/2.8	18°	5–6	32	1.3	4.5	0.13	52	Built-in	78	3-1/16	395	
	FD 135mm f/3.5	18°	4–4	32	1.3	4.5	0.13	52	Built-in	85	3-3/8	325	
	FD 200mm f/2.8	12°	6–7	32	1.5	5	0.16	72	Built-in	134.2	5-5/16	735	1
	FD 200mm f/4	12°	6–7	32	1.5	5	0.15	52	Built-in	121.5	4-13/16	440	1
	FD 300mm f/2.8 L	8°15'	7–9	32	3	10	0.11	48 (drop-in type)	Built-in	245	9-5/8	2,345	5
	FD 300mm f/4 L	8°15'	7–7	32	3	10	0.11	34 (drop-in type)	Built-in	207	8-1/8	1,070	2
FD 300mm f/4	8°15'	6–6	32	3	10	0.11	34 (drop-in type)	Built-in	204	8-1/16	945	2	
FD 300mm f/5.6	8°15'	5–6	32	3	10	0.11	58	Built-in	198.5	7-13/16	635	1	

Type	Lens	Angle of View	Construction	Minimum Aperture	Closest Focusing Distance		Magnification at Closest Focusing Distance	Filter Size (mm)	Hood	Length		Weight		
					(m)	(ft)				(mm)	(in)	(gr.)	(lbs)	(ozs.)
Super Telephoto	FD 400mm f/2.8 L	6°10'	8–10	32	4	15	0.12	48 (drop-in type)	Built-in	348	13-11/16	5,395	11	14
	FD 400mm f/4.5	6°10'	5–6	32	4	15	0.11	34 (drop-in type)	Built-in	287.5	11-5/16	1,280	2	13
	FD 500mm f/4.5 L	5°	6–7	32	5	20	0.14	48 (drop-in type)	Built-in	395	15-9/16	2,610	5	12
	Reflex 500mm f/8	5°	3–6	8	4	15	0.14	34 (drop-in type)	Built-in	146	5-3/4	710	1	9
	FD 600mm f/4.5	4°10'	5–6	32	8	27	0.08	48 (drop-in type)	Built-in	462	18-3/16	3,800	8	6
	FD 800mm f/5.6 L	3°06'	6–7	32	14	45	0.06	48 (drop-in type)	Built-in	577	22-11/16	4,270	9	7
Zoom	FD 20-35mm f/3.5 L	94°–63°	11–11	22	0.5	1.75	0.05–0.08	72	BW-72	84.2	3-5/16	470	1	1
	FD 28-55mm f/3.5-4.5	75°–43°	10–10	22	0.4	1.4	0.09–0.16	52	BW-58C	60.9	2-3/8	220		8
	FD 28-85mm f/4	75°–28°30'	11–13	22	0.9	3	0.04–0.1	72	BW-72	104.1	4-1/8	485	1	1
	FD 35-70mm t/2.8-3.5	63°–34°	10–10	22	1	3.5	0.04–0.07	58	W-69	120	4-3/4	545	1	3
	FD 35-70mm f/3.5-4.5	63°–34°	8–9	22	0.5	1.75	0.08–0.15	52	BW-58C	60.9	2-3/8	200		7
	FD 35-105mm f/3.5-4.5	63°–23°30'	11–14	22	1.2	3.96	0.036–0.103	58	BW-58B	83.7	3-5/16	345		12
	FD 50-135mm f/3.5	46°–18°	12–16	32	1.5	5	0.04–0.11	58	BS-58	125.4	4-15/16	650	1	7
	FD 50-300mm f/4.5 L	46°–8°15'	13–16	32	2.5	8	0.03–0.14	34 (drop-in type)	S-100	250	9-13/16	1,820	4	
	FD 70-210mm f/4	34°–11°45'	9–12	32	1.2	4	0.08–0.23	58	BT-58	151	5-15/16	645	1	7
	FD 75-200mm f/4.5	32°11'–12°	8–12	32	1.8	6	0.05–0.13	52	BT-52B	123	4-13/16	510	1	2
	FD 80-200mm f/4 L	32°–12°	12–14	32	1.2	3.96	0.09–0.22	58	BT-58	153	6	675	1	6
	FD 85-300mm f/4.5	28°30'–8°15'	11–15	32	2.5	8	0.04–0.15	Series IX	Built-in	246.8	9-11/16	1,635	3	10
	FD 100-300mm f/5.6 L	24°–8°15'	10–15	32	2	6.6	0.06–0.18	58	BT-58	172	6-3/4	710	1	9
	FD 100-300mm f/5.6	24°–8°15'	9–15	32	2	6.6	0.06–0.18	58	BT-58	172.2	6-3/4	705	1	9
FD 100-300mm f/5.6	24°–8°15'	9–14	32	2	7	0.06–0.18	58	BT-58	207	8-1/8	830	1	13	
FD 150-600mm f/5.6 L	16°20'–4°10'	15–19	32	3	10	0.07–0.26	34 (drop-in type)	Built-in	468	18-7/16	4,260	9	6	
Autofocus	FD 35-70mm f/4 AF	63°–34°	8–8	22	(0.5)	(1.8)	0.08–0.15	52	–	84.5	3-5/16	645	1	7
Extender	Extender FD2x-A	–	4–6	–	–	–	–	–	–	35.2	1-3/8	210		7
	Extender FD2x-B	–	5–7	–	–	–	–	–	–	43.9	1-11/16	250		9
	Extender FD1.4x-A	–	3–4	–	–	–	–	–	–	34.6	1-3/8	210		7
Macro	Macro FD 50mm f/3.5	46°	4–6	32	23.2(cm)	9.1(in.)	0.5	52	BW-52A	57	2-1/4	235		8
	Macro FD 100mm f/4	24°	3–5	32	0.45	1.48	0.5	52	BT-52	95	2-3/4	455	1	
	Macro FD 200mm f/4	12°	6–9	32	0.58	1.9	1	58	Built-in	182.4	7-3/16	780	1	12
Soft Focus	Softfocus FD 85mm f/2.8	28°30'	4–6	22	8	2.75	0.13	58	BT-58	69.6	2-3/4	375		13
Tilt and Shift	TS 35mm f/2.8	63° (Shift 79°)	8–9	22	0.3	1	0.19	58	BW-58B	74.5	2-15/16	550	1	3
Macro-photo	Macrophoto 20mm f/3.5	–	3–4	22	–	–	–	–	–	20	13/16	30		1
	Macrophoto 35mm f/2.8	–	4–6	22	–	–	–	–	–	22.5	7/8	56		2

Lens weight and length are for lens alone: they do not include lens caps, hood (optional) or tripod mount (if applicable)

Subject to change without notice

Canon

CANON INC. 7-1, Nishi-Shinjuku 2-Chome, Shinjuku-ku, Tokyo 163, Japan
Mailing address: P.O. Box 5050, Dai-ichi Seimei Building, Tokyo 163, Japan

- U.S.A. ————— **CANON U.S.A., INC. HEADQUARTERS**
One Canon Plaza, Lake Success, N.Y. 11042, U.S.A.
CANON U.S.A., INC. ATLANTA OFFICE
5625 Oakbrook Parkway Norcross, Ga. 30093, U.S.A.
CANON U.S.A., INC. CHICAGO OFFICE
100 Park Blvd. Itasca, Il. 60143-2693, U.S.A.
CANON U.S.A., INC. LOS ANGELES OFFICE
123 Paularino Avenue East, Costa Mesa, Cal. 92626, U.S.A.
CANON U.S.A., INC. SANTA CLARA BRANCH
4000 Burton Drive, Santa Clara, Cal. 95054, U.S.A.
CANON U.S.A., INC. DALLAS OFFICE
3200, Regent Blvd., Irving, Tex. 75063-3145, U.S.A.
CANON U.S.A., INC. HONOLULU BRANCH
Bldg. B-2, 1050 Ala Moana Blvd., Honolulu, Hawaii 96814, U.S.A.
CANON U.S.A., INC. WASHINGTON D.C. BRANCH
5701 General Washington Drive Alexandria, Va. 22312, U.S.A.
- CANADA ————— **CANON CANADA INC. HEADQUARTERS**
6390 Dixie Road, Mississauga, Ontario L5T 1P7, Canada
CANON CANADA INC. MONTREAL SERVICE CENTRE
10652 Côte de Liesse, Lachine, Quebec H8T 1A5, Canada
CANON CANADA INC. CALGARY OFFICE
2828, 16th Street, N.E. Calgary, Alberta T2E 7K7, Canada
- EUROPE, AFRICA
& MIDDLE EAST ————— **CANON EUROPA N.V.**
P.O. Box 7907, 1008 AC Amsterdam, The Netherlands
CANON FRANCE-PHOTO CINEMA S.A.
30, boulevard Vital-Bouhot, Ile de la Jatte, 92521 Neuilly-sur-Seine, France
CANON UK LTD.
Units 4 & 5, Brent Trading Centre, North Circular Road, London NW10 0JF, United Kingdom
CANON EURO-PHOTO G.m.b.H
Linsellesstraße 142-156, D-4156 Willich 3, West Germany
- CENTRAL &
SOUTH AMERICA ————— **CANON LATIN AMERICA, INC. DEPTO. DE VENTAS**
Apartado 7022, Panamá 5, República de Panamá
CANON LATIN AMERICA, INC. CENTRO DE SERVICIO Y REPARACION
Apartado 2019, Zona Libre de Colón, República de Panamá
- SOUTHEAST ASIA ————— **CANON HONG KONG TRADING CO., LTD.**
Room 1101-3 & 1121-2, Peninsula Centre, 67 Mody Road, Tsimshatsui East, Kowloon,
Hong Kong
CANON SINGAPORE PTE. LTD.
95 South Bridge Road #13-01/15, South Bridge Centre, Singapore 0105
- OCEANIA ————— **CANON AUSTRALIA PTY. LTD.**
Unit 1/37, Waterloo Road, North Ryde (Macquarie Park), N.S.W. 2113, Australia
- JAPAN ————— **CANON SALES CO., INC.**
11-28, Mita, 3-Chome, Minato-ku, Tokyo 108, Japan